

BASIC INFORMATION ABOUT THE PRODUCT



- Insert with an enlarged, deep rectangular combustion chamber enabling large loads.
- Tilttable cast iron grate for easy cleaning of the fireplace.
- Decorative heat-resistant DECOR glass as standard (operating temperature up to 800°).
- A new type of guillotine with service access (2 types of service access depending on the size of the insert).
- The exhaust gas after-combustion system is located in the upper part of the combustion chamber, above the grate
- clean glass system: air guide with air curtain.
- Steel doors made of a special profile ensuring stiffness and resistance to high temperatures.
- The insert elements are produced using modern CNC devices (2D, 3D laser, press brakes).
- The insert jacket is made of P265GH boiler steel according to EN 10028-2. The exhaust gas after-combustion system is located in the upper part of the combustion chamber, above the grate.

Nominal power [kW]	19
Heating load range [kW]	9,5-24,5
Thermal efficiency [%]	75,5
CO emissions (at 13% O ₂) [g/m ³]	0,035
Pollen emission [g/m ³]	1,217
Average fuel consumption [kg/h]	5,9
Recommended dimensions of outlet grilles [cm ²]	1330-1520
Recommended dimensions of inlet grilles [cm ²]	760-1240
Glass dimensions [mm]	1053x430
Flue diameter [mm]	198
Inlet diameter [mm]	123
Weight [kg]	409
Efficiency factor	100,5



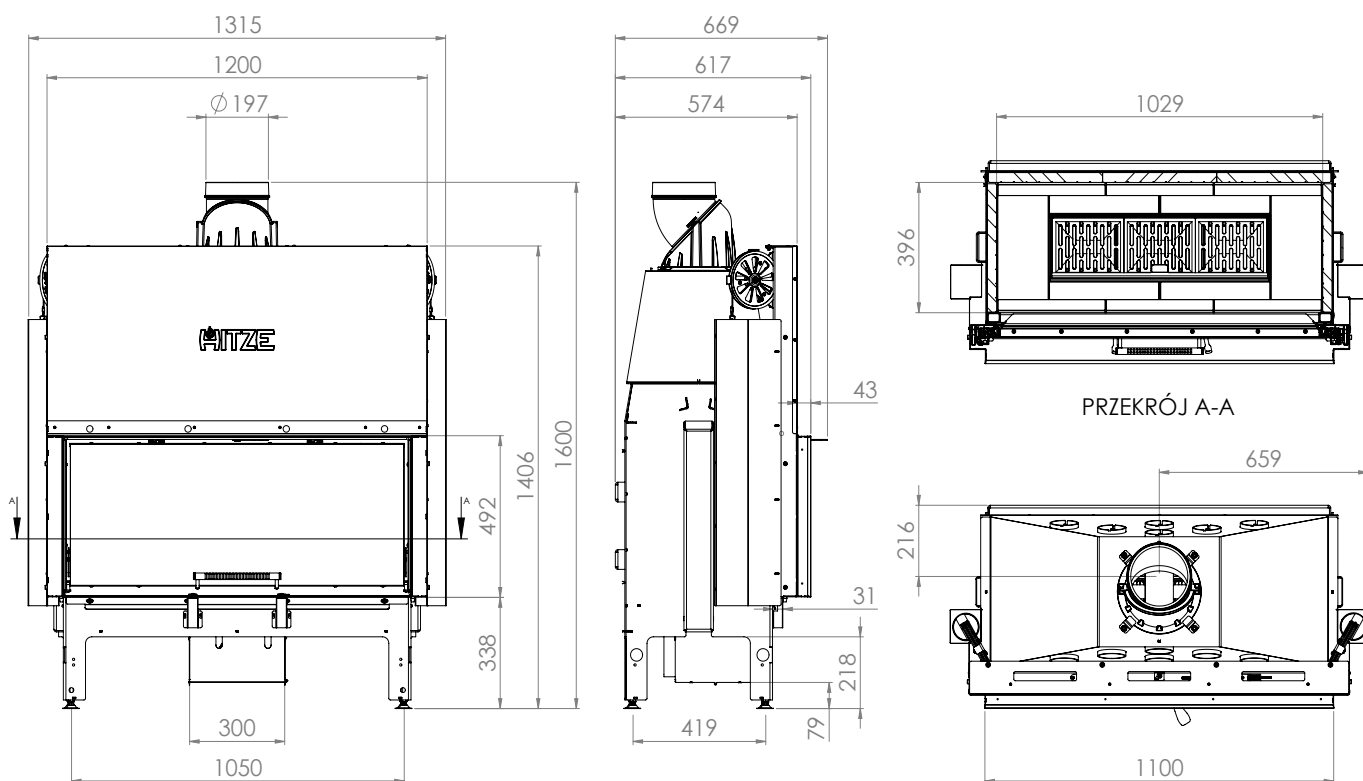

ARDENTE

105x43.G