

BASIC INFORMATION ABOUT THE PRODUCT



- Insert with an enlarged, deep rectangular combustion chamber enabling large loads.
- Tilttable cast iron grate for easy cleaning of the fireplace.
- Decorative heat-resistant DECOR glass as standard (operating temperature up to 800°).
- A new type of guillotine with service access (2 types of service access depending on the size of the insert).
- The exhaust gas after-combustion system is located in the upper part of the combustion chamber, above the grate
- clean glass system: air guide with air curtain.
- Steel doors made of a special profile ensuring stiffness and resistance to high temperatures.
- The insert elements are produced using modern CNC devices (2D, 3D laser, press brakes).
- The insert jacket is made of P265GH boiler steel according to EN 10028-2. The exhaust gas after-combustion system is located in the upper part of the combustion chamber, above the grate.

Nominal power [kW]	17
Heating load range [kW]	8,5-22
Thermal efficiency [%]	79
CO emissions (at 13% O2) [g/m3]	0,034
Pollen emission [g/m3]	0,903
Average fuel consumption [kg/h]	5,1
Recommended dimensions of outlet grilles [cm2]	1190-1360
Recommended dimensions of inlet grilles [cm2]	680-1100
Glass dimensions [mm]	903x410
Flue diameter [mm]	198
Inlet diameter [mm]	123
Weight [kg]	363
Efficiency factor	105,6



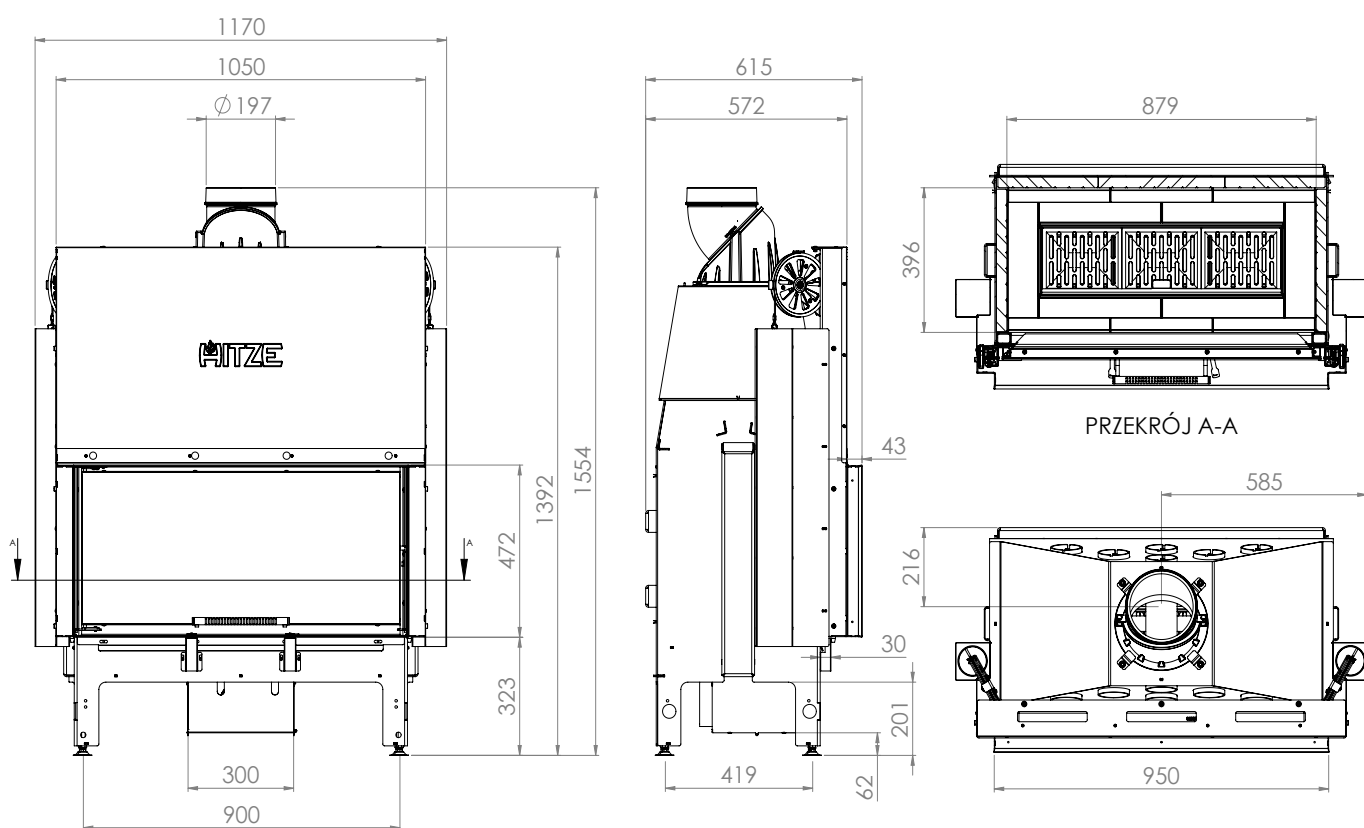

# ARDENTE

## 90x41.G