

BASIC INFORMATION ABOUT THE PRODUCT



- A timeless, compact freestanding fireplace, ideal as an additional heat source.
- Suitable for open spaces.
- High thermal efficiency for economical wood burning.
- Paint finish designed for high temperatures.
- Air curtain on the front window and aeration system on the rear wall.
- Two-stage aeration with a single damper to regulate the air supply.
- Combustion chamber lined with accumulation material with grateless hearth.
- Optional fresh air intake for compatibility with mechanical ventilation.
- Double-polished fireplace ceramics with heat resistance of 800°C and stylish DECOR frame.
- Minimalist steel vertical grate.

Nominal power [kW]	5,5
Heating load range [kW]	2,7 - 7
Thermal efficiency [%]	79
CO emissions (at 13% O2) [g/m3]	1,212
Pollen emission [g/m3]	0,017
Average fuel consumption [kg/h]	1,7
Glass dimensions [mm]	398 x 338
Flue diameter [mm]	129
Weight [kg]	75
Efficiency factor	105,6



GATTO ME

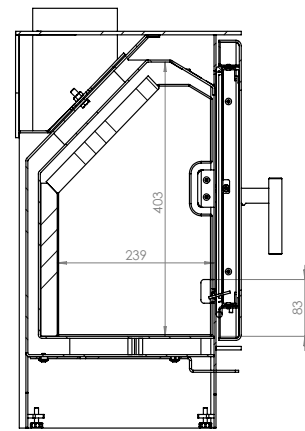
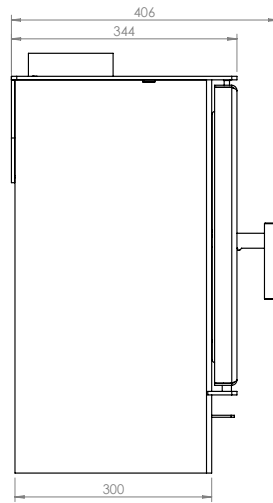
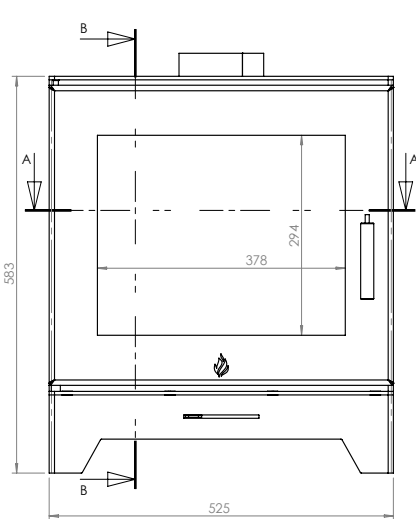

PRZEKRÓJ B-B
SKALA 1 : 7

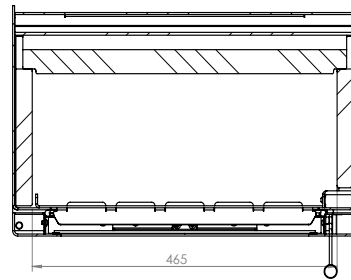
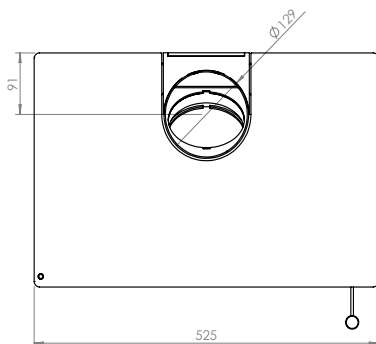

PRZEKRÓJ A-A
SKALA 1 : 7

GATTO ME
Masa: 75kg

GATTO ME